

GESTRA Pump Trap

Type UNA 25-PK DN 40 / 1 1/2"

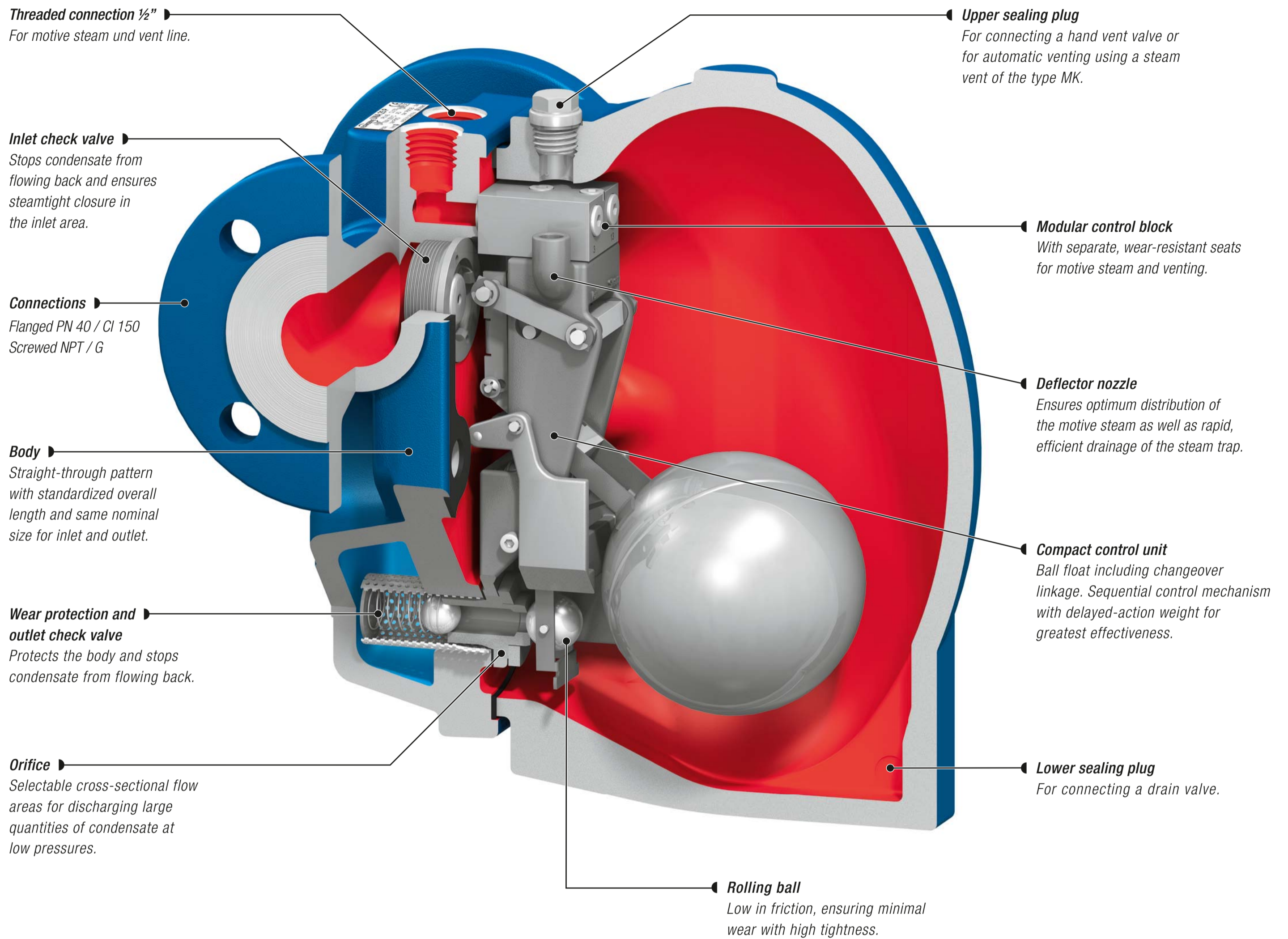

GESTRA



Functional Principle

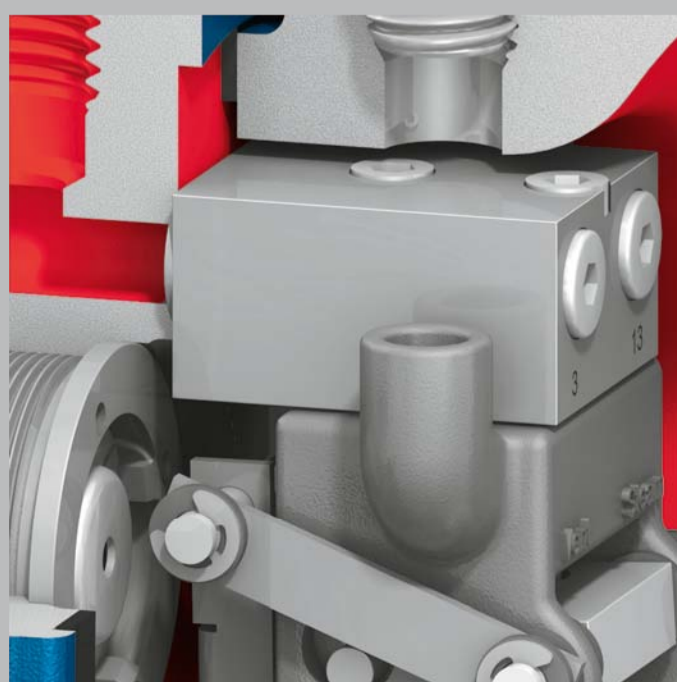

Modular control block
The design of the control block with exchangeable seats for different pressures permits the best possible utilization of the available motive steam pressure. Flexibility of use is enhanced, and the potential pumping capacity of the UNA 25-PK can be exploited fully.

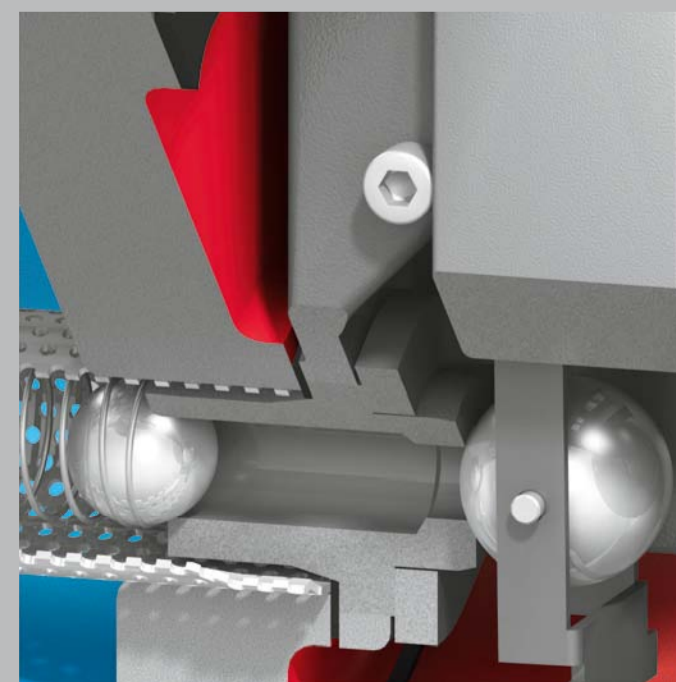

Orifice with rolling ball
Various orifices for the UNA 25-PK guarantee an optimum adaptation to the customer's operational conditions. Like all the other GESTRA float traps, the UNA 25-PK always offers the highest possible capacity for discharging condensate at various differential pressures.

Optimally coordinated pumping and trapping modes

